



SNOWDRAGON INDUSTRIAL CO.,LTD

Customer Service :+86-755-83918797 +86-755-28269297

Fax: +86-755-83062997

Websites: www.snowdragonledhk.com www.snowdragonledproduct.com

LED Product Specification

| | |
|----------------------|------------------|
| Company Name : | |
| Product Number: | SD346RDR-OK-S1-P |
| Document Number : | |
| Product Description: | 3mm Oval LED |

| CUSTOMER APPROVED BY | | | |
|-------------------------------|--|--|--|
| Department | | | |
| Checked | | | |
| Signature | | | |
| Final confirmation of results | | | |



Applications :

- Indoor and outdoor full color display
- Billboards
- Decorative Lighting
- Indicator

Features:

- 3mm Oval LED
- Lens Color: colored mist
- LED Color: Red
- Half-power angle: 100 °
- Chip Material: AlGaInP

Package Dimensions

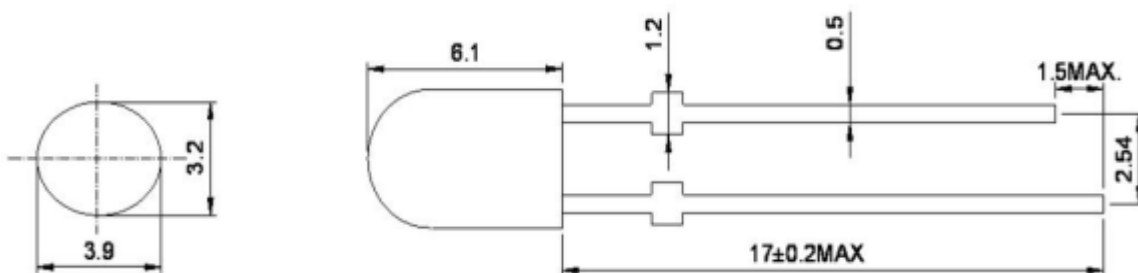

Note:

1. All dimensions are in mm
2. If no special instructions tolerance range ± 0.25mm
3. Described in the technical data sheet are subject to change without notice.
4. The semiconductor device is static sensitive components, wear protective equipment pick up static electricity, all the machines, please do ground handling equipment.

Electrical / Optical Characteristics at TA=25°C

| Symbol | Parameter | Device | Min. | Typ. | Max. | Units | Test Conditions |
|----------|--------------------|--------|------|------|------|-------|-----------------|
| VF [1] | Forward Voltage | Red | - | 2 | - | V | IF=20mA |
| IR | Reverse Current | | - | | 10 | uA | VR = 5V |
| Iv | Luminous intensity | | 910 | - | 1210 | mcd | IF=20mA |
| λd | Peak wavelength | | 621 | - | 625 | nm | IF=20mA |
| 2θ1/2H-H | Viewing Angle | | - | 105 | - | deg | IF=20mA |
| 2θ1/2V-V | Viewing Angle | | - | 49 | - | deg | IF=20mA |

Absolute Maximum Ratings at TA=25°C

| Parameter | Symbol | Maximum size | Units |
|-----------------------|--------|----------------|-------|
| Power dissipation | PD | 110 | mW |
| Reverse Current | IF | 30 | mA |
| Peak Forward Current | IFP | 100 | mA |
| Reverse Voltage | VR | 5 | V |
| Operating Temperature | | -40°C To +85°C | |
| Storage Temperature | | -40°C To +85°C | |

Pulse Width. \leq 0.1msec ; Duty Cycle \leq 1/10

Typical light - electric curve:

Forward Current vs. Dominant wavelength

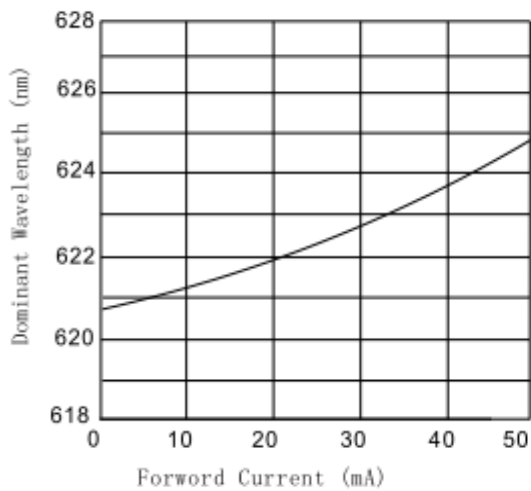

Relative Intensity vs. Ambient Temperature

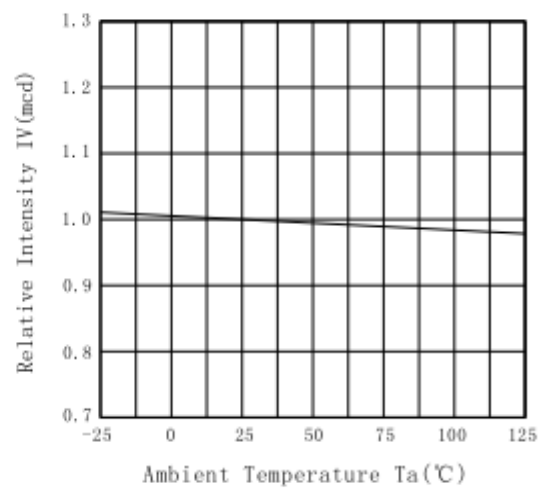

Forward Current vs. Forward Voltage

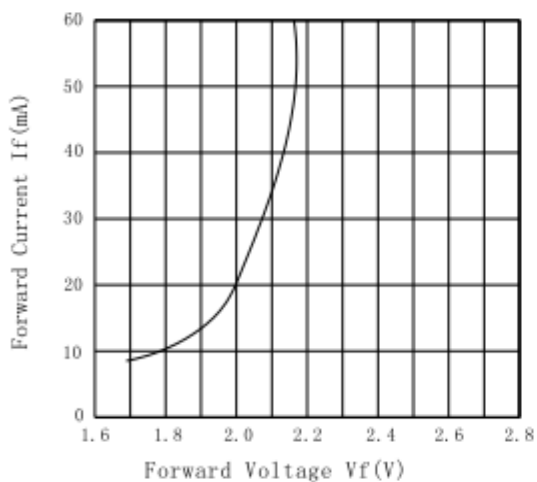

Forward Voltage vs. Ambient Temperature

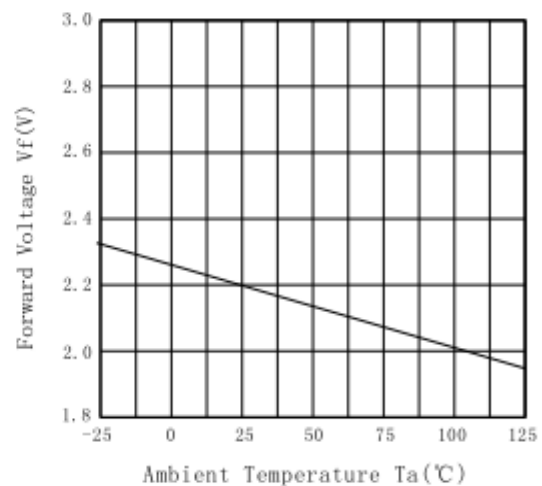

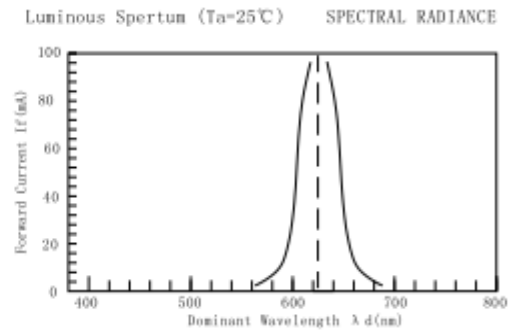
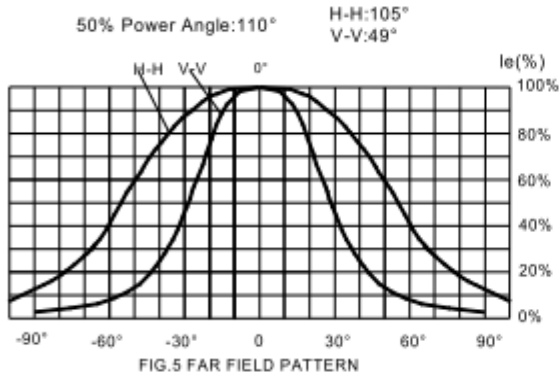

Drying agent

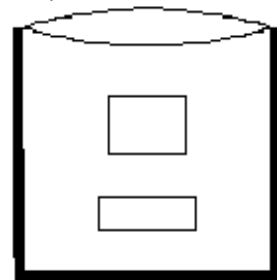

Anti-static Aluminum Bag
100PCS/Bag

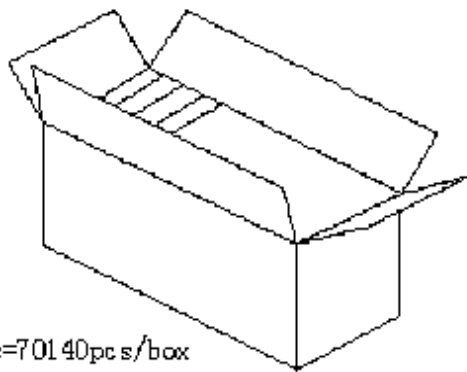

BOX(70包)
70×100PCS=70140PCS/box