



Snowdragon Industrial Co.,Ltd

DATA SHEET

Model NO.:SD-S5050DWCU_K1

ENG. NO.:2014030307

Features:

- ※ **5.0*5.0mm Chip SMD**
- ※ **Collid Color: Yellow**
- ※ **Emission Color: Warm White**
- ※ **Viewing Angle: 120°**

PREPARED BY	CHECKED BY	APPROVED BY
CUSTOMER APPROVED SIGNATURES		

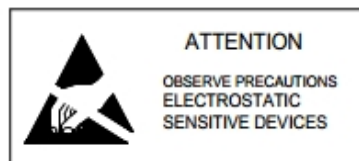

1. 外形尺寸 Dimensions

单位(Units):毫米(mm)

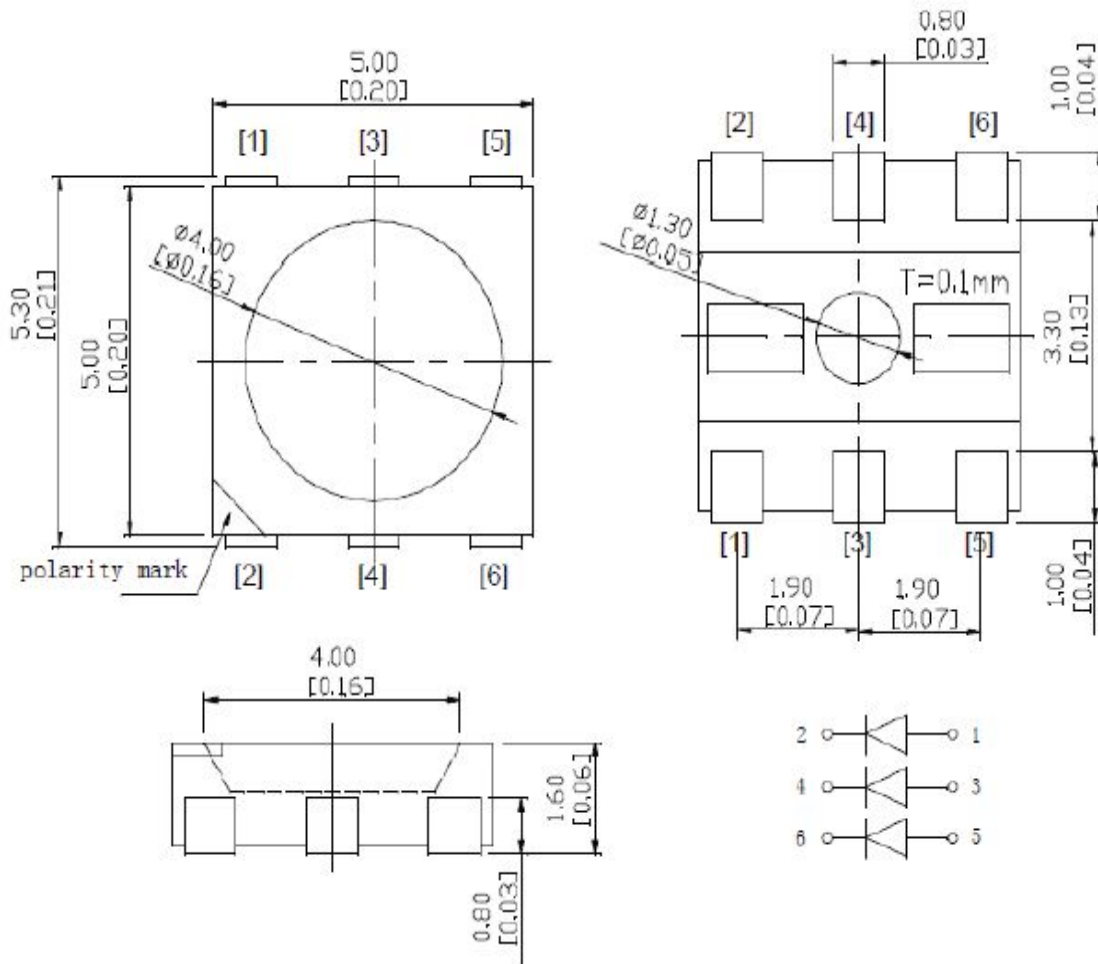

注意:

所有尺寸单位为 mm ， 如无特殊说明误差范围为 $\pm 0.1\text{mm}$

All dimensions are in mm tolerance is $\pm 0.1\text{mm}$ unless otherwise noted.

2. 光电特性 Electrical / Optical characteristics

(1) 最大限度值 Absolute Maximum Ratings (TA=25±5°C)

项目Item	符号 Symbol	最大额定值 Absolute Maximum Rating	单位 Unit
正向电流Forward Current	IF	60	mA
正向峰值电流Pulse Forward Current	IFP	150	mA
反向电压Reverse Voltage	VR	5	V
功率消耗Power Dissipation	PD	100	mW
工作温度Operating Temperature	Topr	-40°C To +85°C	°C
贮藏温度Storage Temperature	Tstg	-40°C To +85°C	°C
焊接温度Soldering Temperature	Tsld	Reflow Soldering: 260°C Hand Soldering : 350°C	for 10sec. for 3sec.

1/10 周期, 0.1 msec 脉宽

IFP Conditions : 1/10 Duty Cycle, 0.1 msec Pulse Width.

(2) 样品光电参数 Initial Electrical/Optical Characteristics (TA=25±5°C)

符号 Symbol	项目 Item	单位 Units	最小值 Min.	规格值 Typ.	最大值 Max.	测试条件 Test Conditions
VF	正向电压 Forward Voltage	V	3.0		3.4	IF=20mA
IR	反向电流 Reverse Current	uA			10	VR=5V
2θ ½	发光角度 Viewing Angle	°		120°		IF=20mA
∅	光通亮 Luminous flux	lm	14		16	IF=20mA
TC	色温 Colour Temperature	k	6000		7000	IF=20mA
RA	显色指数 Color Rendering Index	Ra	65		70	IF=20mA

正向电压允许误差± 0.05V Tolerance of measurement of Vf is ±0.05 V.

亮度允许误差± 10% Luminous Intensity Measurement allowance is ± 10%.

3. 特性曲线 Characteristic curve

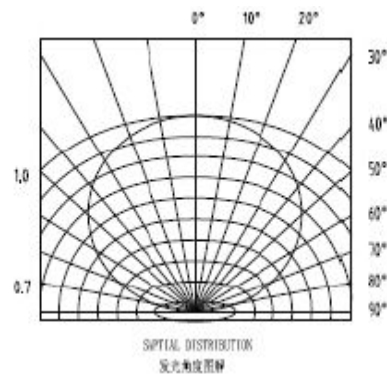
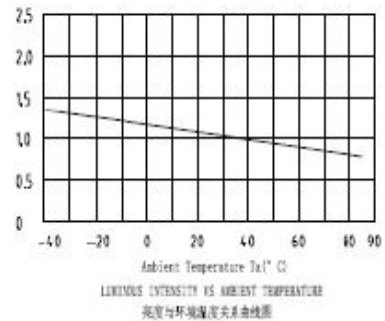
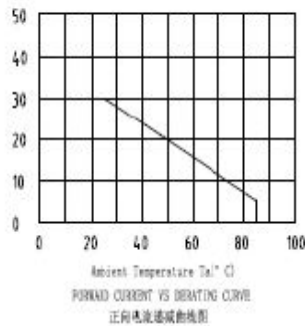
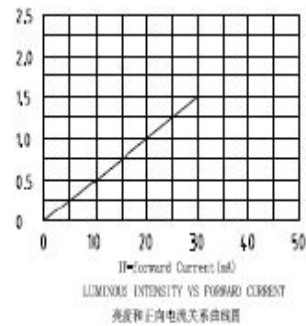
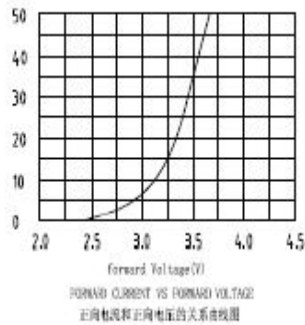
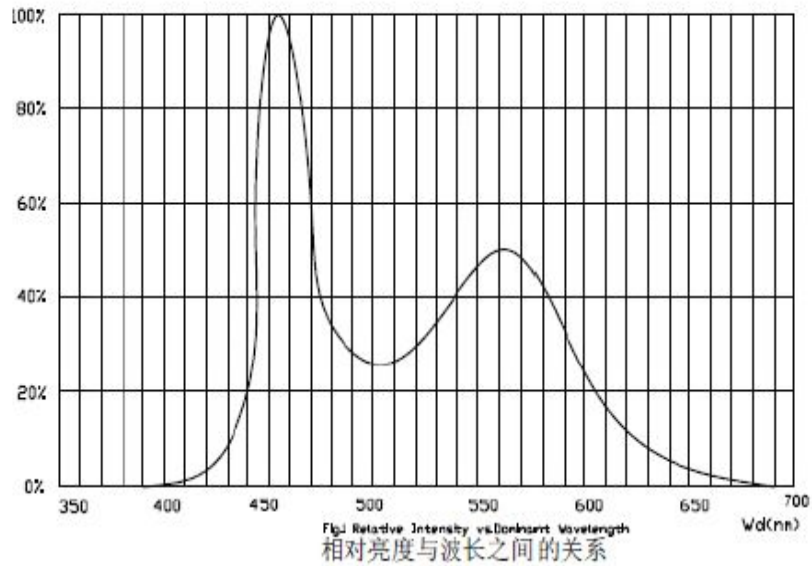

4. 可靠性 RELIABILITY

(1)测试项目及结果 Test Items and Results

序号	试验项目	参考标准	试验条件	持续时间	取样数	接收水准（不合格数量/抽样总数）
1	温度循环	JEITA ED-4701 100 105	-40℃～25℃ ～100℃～25℃ 30分钟 5分钟 30分钟 5分钟	循环100回合	50	0/50
2	冷热冲击	MIL-STD-202 G	-40℃～100℃ 15分钟 15分钟	循环500回合	50	0/50
3	高温储存	JEITA ED-4701 200 201	Ta=100℃	1000小时	50	0/50
4	低温储存	JEITA ED-4701 200 202	Ta=-40℃	1000小时	50	0/50
5	常温寿命试验		Ta=25±5℃ IF=20mA	1000小时	50	0/50
6	高温高湿寿命试验		Ta=60℃ RH=85% IF=20mA	1000小时	50	0/50
7	可焊性（回流焊）	JEITA ED-4701 300 303	Tsol=235℃±5℃,5秒 使用助焊剂	焊接一次，5秒	10	0/10
8	耐焊性（回流焊）	JEITA ED-4701 300 301	Tsol=260℃,10秒 预处理:35℃ 95%RH 96小时	焊接二次，每次10秒	10	0/10

5. 注意事项 Cautions

(1) 焊接条件 Soldering Conditions

本产品最多只可回焊两次,且在首次回焊后须冷却至室温之后方可进行第二次回焊.

Number of reflow process shall be less than 2 times and cooling process to normal temperature is required between first and Second soldering process.

推荐焊接条件(Recommended soldering conditions)

回流焊接 Reflow Soldering			手工焊接 Hand Soldering	
	有铅 Lead Solder	无铅 Lead-free Solder	温度 Temperature	350°C Max.
预热温度 Pre-heat	140 ~ 160°C	180 ~ 200°C	焊接时间 Soldering time	3 sec. Max. (one time only)
预热时间 Pre-heat time	120 sec. Max.	120 sec. Max.		
峰值温度 Peak temperature	230°C Max.	260°C Max.		
焊接时间 Soldering time	10 sec. Max.	10 sec. Max.		
条件 Condition	参考下图	参考下图		

有铅回焊 (Lead Solder)

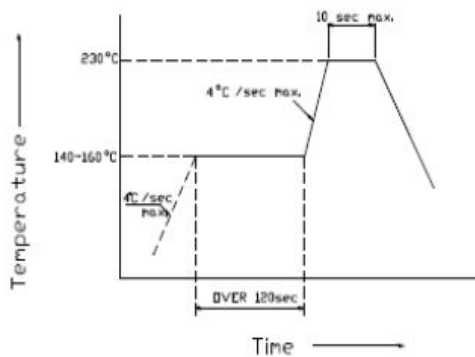

无铅回焊 (Lead-Free Solder)

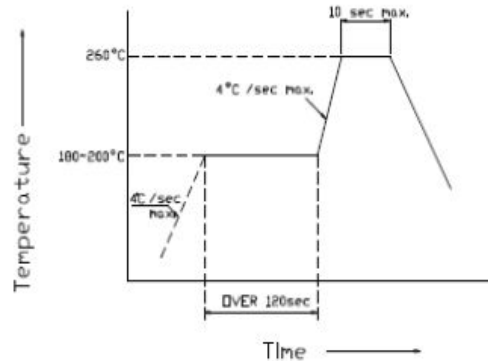

(2) 静电 Static Electricity

触摸 LED 时,推荐使用防静电手腕带或防静电手套.

It is recommended that a wrist band or an anti-electrostatic glove be used when handling the LEDs.

所有装置、设备、机器均应接地.

All devices, equipment and machinery must be properly grounded.

静电损坏的 LED 会显示出异常特征:正向电压变低或在低电流时死灯.标准: $I_F=0.5\text{mA}$ 时, $V_F > 2.0\text{V}$

Damaged LEDs will show some unusual characteristics such as the forward voltage becomes lower, or the LEDs do not light at the low current. Criteria : ($V_F > 2.0\text{V}$ at $I_F=0.5\text{mA}$)

(3) 防潮包装 Moisture Proof Package

使用防潮包装

It is recommended that moisture proof package be used

(4) 储藏 Storage

打开包装袋之前,LED 在温度为 30°C 或更低湿度 70%RH 以下,可保存一年.

Before opening the package ,The LEDs should be kept at 30°C or less and 70%RH or less. The LEDs should be used within a year.

(1) 打开包装之后,应在 24hrs 内焊接完毕.

After opening the package, The LEDs should be soldered within 24 hours (1days) after opening the package.

(2) 使用注意事项

Cautions:

6.1.在开包装之前,请先检查包装袋有无漏气,如果有漏气现象,请退回我司重新烘烤除湿包装后再使用。

Please check if there is air leak before opening the package, if so, please return the goods back to take drying process for later using.

6.2 抽真空包装材料未超过 15 天可正常使用, 包装袋开启后,产品必须:

Products can be used within 15days after packaging, after that, they must be:

6.2.1 在 24hrs 内未焊接完毕。

Soldered within 24 hrs

6.2.2 要在规定环境条件中使用: 温度:30°C以内 湿度:60%RH 以下

Used in the condition: 30°C within and 60%RH below

6.2.3 存储低于 30%RH。

Stored in 30%RH for moisture below.

6.3.抽真空包装材料超过 30 天(含)以上未使用,再使用时需重新拆铝箔袋取出烘烤 85°C/12H 除湿后才可使用。

Products cannot be used for and over 30days after being packaged unless opening the package and take drying our process in 85°C/12H.

6.4.抽真空包装材料超过 60 天(含)以上未使用,请退回我司重新烘烤除湿包装后再使用。

Products not be used for or over 60days after being packaged please return back to take drying out and packaging process for forward using.

6.5.材料拆装后使用时间超过 24H 未用完,需烘烤 85°C/6H 除湿后才可使用。

Products not be used after opening the package need to be dried out for 85°C/6H

1. 包装 PACKAGING

- (1) LEDS 在装带之后纸箱包装. The LEDs are packed in cardboard boxes after taping.
- (2) 装带规格 Taping Specifications (单位:毫米 Units:mm)

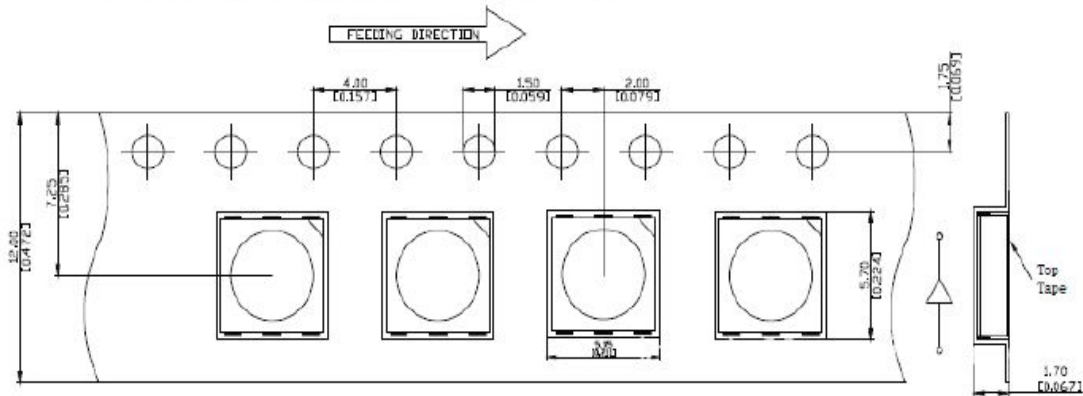

(3) 卷轴尺寸 Reel Dimension

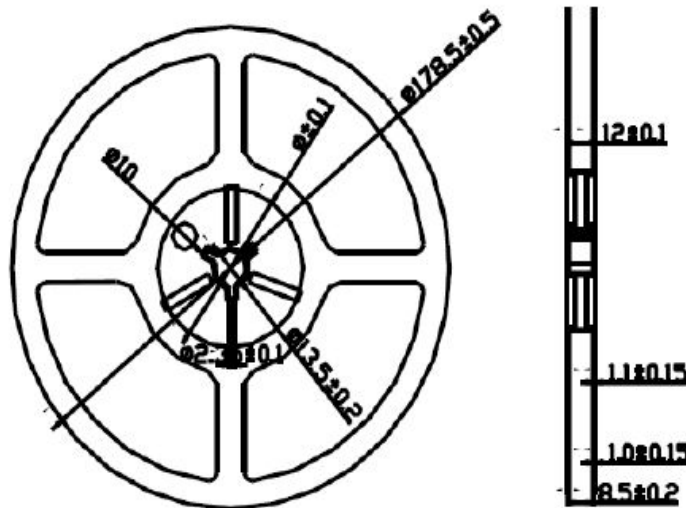

每卷数量 1000 个/卷 PACKAGE: 1000Pcs/Reel

- (4) 最小包装标签注明以下:产品名称,批号,参数范围,数量.
The label on the minimum packing unit shows ; Part Number, Lot Number, Ranking, Quantity.
- (5) 请注意防水防潮
Keep away from water, moisture in order to protect the LEDs.
- (6) 须采取适当防护措施,以防包装箱跌落或受到强力撞击造成对产品的损伤.
The LEDS may be damaged if the boxes are dropped or receive a strong impact against them. so precautions must be taken to prevent any damage.